

# STRAIGHT RATCHET

## 20686 3/4" x 1/2" Ratchet Attachment



| TOOL #      | RPM      | RPM   | TORQUE |      | WEIGHT |      |
|-------------|----------|-------|--------|------|--------|------|
|             | Fastener | Motor | Inch   | Nm   | Lbs.   | Kg.  |
| 20053-20686 | 72       | 500   | 300    | 33.9 | 2.78   | 1.26 |
| 20054-20686 | 143      | 1000  | 210    | 23.7 | 2.60   | 1.18 |
| 20055-20686 | 286      | 2000  | 130    | 14.7 | 2.93   | 1.33 |

20686 Attachment  
 Shown with 20053 .85 HP  
 500 RPM Motor  
 TOOL # 20053-20686-Gear number

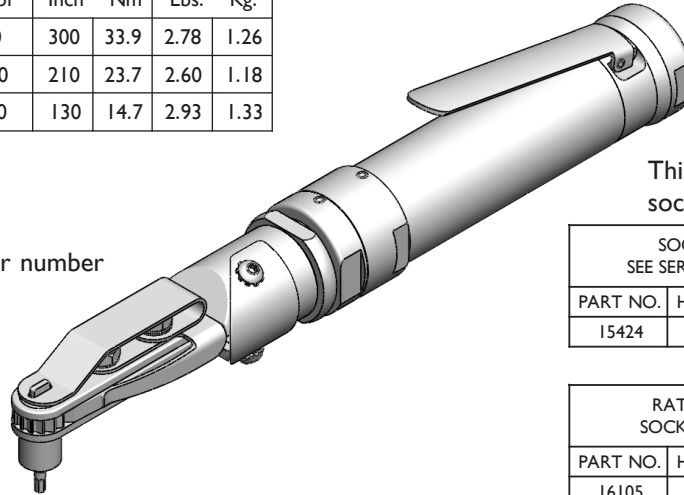

This tool uses series 2/3 sockets and keys Page 71

| SOCKET DRIVER GEAR<br>SEE SERIES 2/3 SOCKET TABLES |          |               |
|--|----------|---------------|
| PART NO.   | HEX SIZE | TYPE          |
| 15424  | 9/32     | SOCKET DRIVER |

| RATCHET GEARS FLUSH<br>SOCKET BUILT INTO GEAR |          |       |
|---|----------|-------|
| PART NO.                                      | HEX SIZE | TYPE  |
| 16105   | 7/32     | FLUSH |
| 16106   | 9/32     | FLUSH |
| 16107   | 5/16     | FLUSH |
| 16108   | 11/32    | FLUSH |
| 16109   | 7/16     | FLUSH |
| 16110   | 3/8      | FLUSH |

| FLUSH HEX KEYS |          |
|----------------|----------|
| PART NO.       | HEX SIZE |
| 18155          | 1/16     |
| 18156          | 5/64     |
| 18157          | 3/32     |
| 18158          | 1/8      |
| 18935          | 5/32     |
| 18936          | 3/16     |

FOR TWELVE POINT CONFIGURATION  
 ADD X TO RATCHET GEAR PART NO.

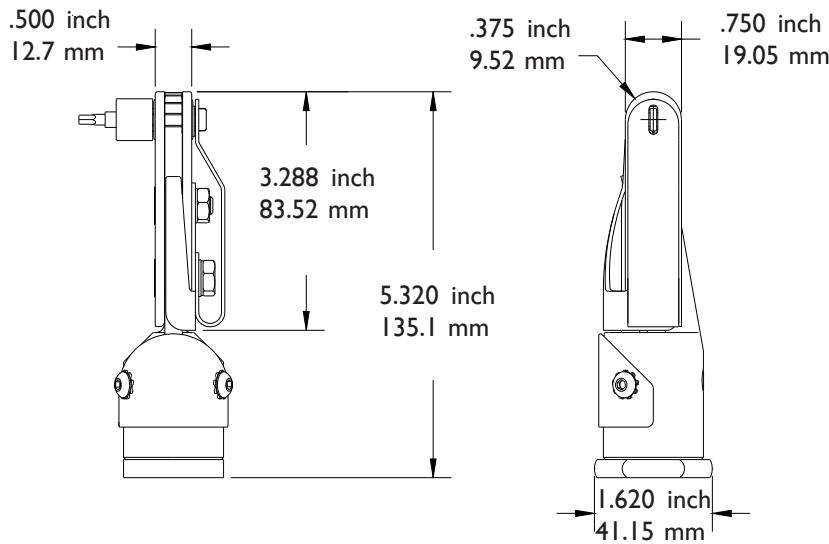

| 500 RPM     | 1000 RPM   | 2000 RPM   |
|-------------|------------|------------|
| 12.463 inch | 12.45 inch | 12.89 inch |
| 316.56 mm   | 316.23 mm  | 327.41 mm  |

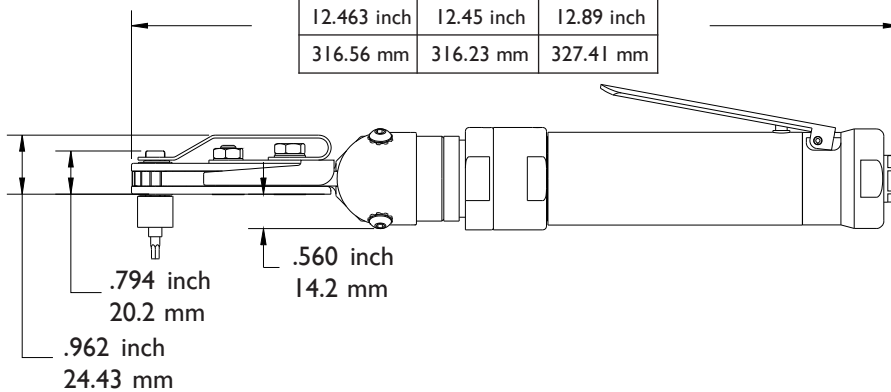

| RATCHET GEARS HEX THRU |             |          |
|------------------------|-------------|----------|
| PART NO.               | HEX SIZE    | TYPE     |
| 15488                  | 7/32        | HEX THRU |
| 9947                   | 1/4         | HEX THRU |
| 10781                  | 9/32        | HEX THRU |
| 1429                   | 5/16        | HEX THRU |
| 1447                   | 7/16        | HEX THRU |
| 1445                   | 11/32       | HEX THRU |
| 1430                   | 3/8         | HEX THRU |
| 1412                   | 3/8-1/2 EXT | HEX THRU |