

STRAIGHT RATCHET

20687 1" x 1/2" Ratchet Attachment



TOOL #	RPM Fastener	RPM Motor	TORQUE		WEIGHT	
			Inch	Nm	Lbs.	Kg.
20053-20687	56	500	400	45.2	2.8	1.27
20054-20687	112	1000	250	28.2	2.6	1.18
20055-20687	223	2000	200	22.6	2.9	1.31

20687 Attachment
 Shown with 20053 .85 HP
 500 RPM Motor
 TOOL # 20053-20687-Gear number

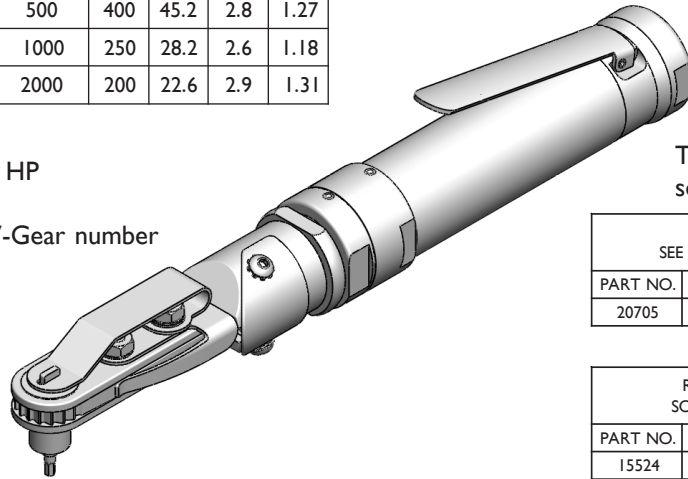

This tool uses series 2/3 sockets and keys Page 71

SOCKET DRIVER GEAR SEE SERIES 2/3 SOCKET TABLES		
PART NO.	HEX SIZE	TYPE
20705	9/32	9/32 SOCKET DRIVER

RATCHET GEARS FLUSH SOCKET BUILT INTO GEAR		
PART NO.	HEX SIZE	TYPE
15524	9/16	FLUSH
15525	1/2	FLUSH
15526	7/16	FLUSH
15527	3/8	FLUSH
15528	11/32	FLUSH
15529	5/16	FLUSH

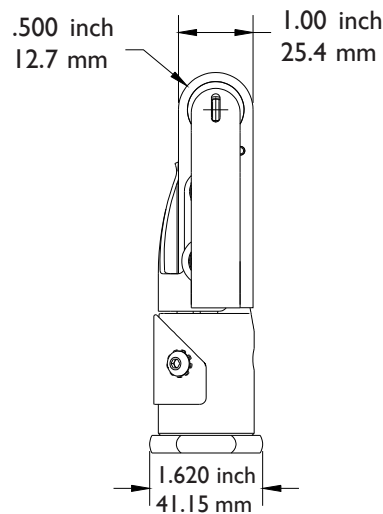
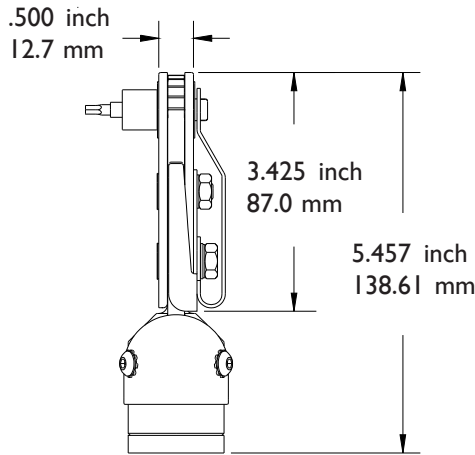

FLUSH HEX KEYS	
PART NO.	HEX SIZE
18155	1/16
18156	5/64
18157	3/32
18158	1/8
18935	5/32
18936	3/16

FOR TWELVE POINT CONFIGURATION
 ADD X TO RATCHET GEAR PART NO.

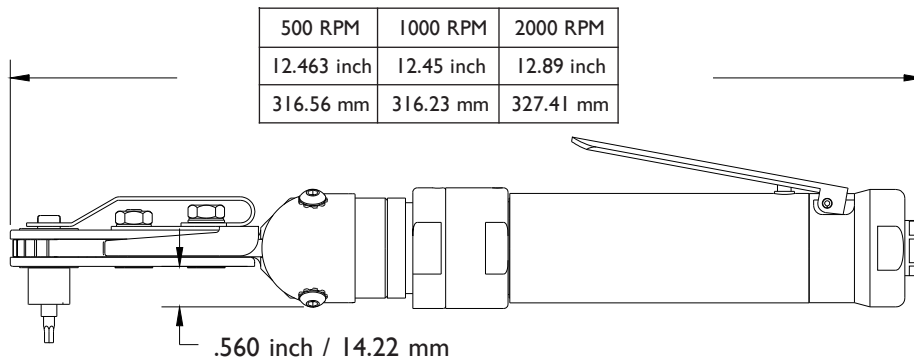

RATCHET GEARS HEX THRU		
PART No.	HEX SIZE	TYPE
10875	9/32	HEX THRU
1495	5/16	HEX THRU
1493	7/16	HEX THRU
1491	11/32	HEX THRU
1487	1/2	HEX THRU
1501	9/16	HEX THRU
1636	3/8	12 PT. THRU