

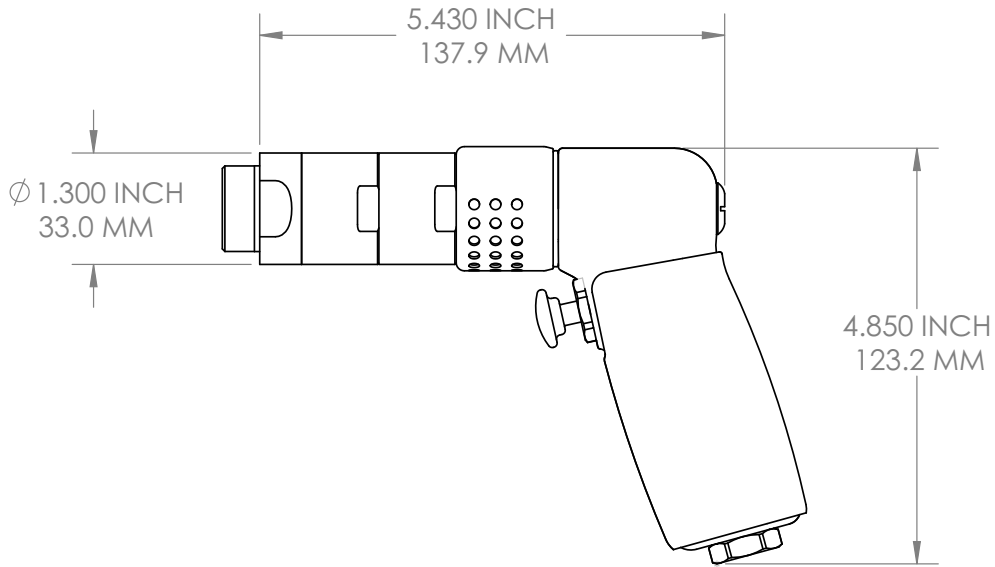

JIFFY MODULAR INSTALLATION MOTOR (JMI) D SERIES, 0.3 H.P., OFFSET HANDLE

RPM	ORDER NUMBER	WEIGHT
150	16839	1.75 LB / .79 KG



250	12387	1.66 LB / .75 KG
500	15421	1.66 LB / .75 KG

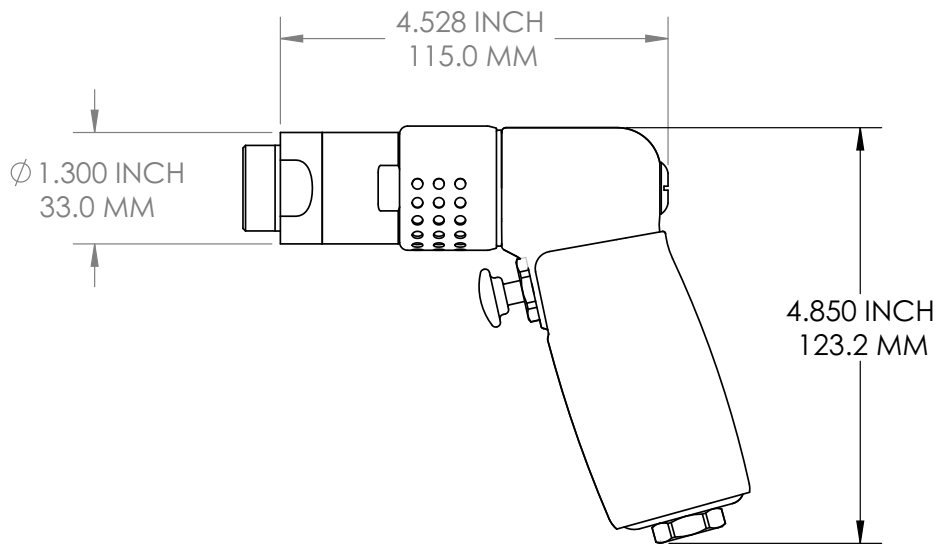

PHONE: 1 775 883 1072 FAX: 1 775 883 4857